



TEST TRANSLATORS

For Outdoor Applications



This series of Test Translators is provided in transmit/receive or transmit/L-band conversions. The rugged outdoor packaging allows mounting in an antenna hub (standard enclosure) or in an outdoor environment (pressurized enclosure). The translator is designed for applications where frequency translation is needed with a minimum of amplitude distortion and delay distortions.

FEATURES

- Minimum amplitude and delay distortion
- High frequency stability
- Low intermodulation distortion
- 30 dB level control, internal calibrated dial
- Low phase noise contribution

OPTIONS

- Digitally controlled attenuators with remote control
- 60 dB total level control
- Input filtering
- Input/output amplifiers
- Synthesized LO to 5 MHz reference
- High frequency stability
- Summary alarm
- Pressurized enclosure

SPECIFICATIONS

| Model Number | Input Frequency (GHz) | Output Frequency (GHz) | LO Frequency (GHz) | Phase Noise | Return Loss (dB) Input | Return Loss (dB) Output |
|--------------------------------------|-----------------------|------------------------|--------------------|-------------|------------------------|-------------------------|
| TRANSMIT BAND TO RECEIVE BAND | | | | | | |
| DN-W-8011 | 5.925–6.425 | 3.7–4.2 | 2.225 | A | 23 | 23 |
| DN-W-8011-1 | 5.845–6.425 | 3.62–4.2 | 2.225 | A | 23 | 23 |
| DN-W-8011-2 | 5.95–6.525 | 3.625–4.2 | 2.325 | A | 23 | 23 |
| DN-W-8011-3 | 5.84–5.93 | 2.55–2.63 | 3.3 | A | 23 | 23 |
| DN-W-8011-4 | 6.725–7.025 | 4.5–4.8 | 2.225 | A | 23 | 23 |
| DN-W-8-7 | 7.9–8.4 | 7.25–7.75 | 0.65 | A | 20 | 20 |
| DN-W-8-7-1 | 7.9–8.4 | 7.25–7.75 | 0.725 | A | 20 | 20 |
| DN-W-13-10.95 | 12.75–13.25 | 10.7–11.2 | 2.05 | A | 20 | 20 |
| DN-W-13.9-12.6 | 13.75–14.0 | 12.5–12.75 | 1.247 | A | 20 | 20 |
| DN-W-14-10 | 14.0–14.25 | 10.95–11.2 | 3.05 | A | 20 | 20 |
| DN-W-14-11 | 14.0–14.25 | 11.45–11.7 | 2.55 | A | 20 | 20 |
| DN-W-14-11-1 | 14.25–14.5 | 11.45–11.7 | 2.8 | A | 20 | 20 |
| DN-W-14-11-2 | 14.25–14.5 | 10.95–11.2 | 3.3 | A | 20 | 20 |
| DN-W-14-11-3 | 14.25–14.5 | 11.45–11.7 | 2.795 | A | 20 | 20 |
| DN-W-14-11.3 | 14.25–14.5 | 11.2–11.45 | 3.05 | A | 20 | 20 |
| DN-W-14-11.71 | 14.0–14.5 | 11.46–11.96 | 2.54 | A | 20 | 20 |
| DN-W-14-11.8 | 14.0–14.25 | 11.7–11.95 | 2.295 | A | 20 | 20 |
| DN-W-14-12 | 14.0–14.5 | 11.7–12.2 | 2.3 | A | 20 | 20 |
| DN-W-14-12.45 | 14.0–14.5 | 12.2–12.7 | 1.8 | A | 20 | 20 |
| DN-W-14-12.5 | 14.0–14.5 | 12.25–12.75 | 1.75 | A | 20 | 20 |
| DN-W-14-12.5-1 | 14.0–14.5 | 12.25–12.75 | 1.748 | A | 20 | 20 |
| DN-W-14-12.5-2 | 14.0–14.5 | 12.25–12.75 | 1.73 | A | 20 | 20 |
| DN-W-14-12.6 | 14.0–14.25 | 12.5–12.75 | 1.495 | A | 20 | 20 |
| DN-W-14-12.6-1 | 14.0–14.25 | 12.5–12.75 | 1.5 | A | 20 | 20 |
| DN-W-14-12.6-2 | 14.0–14.25 | 12.5–12.75 | 1.498 | A | 20 | 20 |
| DN-W-14.1-11.3 | 13.75–14.5 | 10.95–11.7 | 2.8 | A | 20 | 20 |
| DN-W-14.65-11.85 | 14.5–14.8 | 11.7–12.0 | 2.79782 | A | 20 | 20 |
| DN-W-17.55-11.95 | 17.3–17.8 | 11.7–12.2 | 5.6 | B | 20 | 20 |
| DN-W-17-12 | 17.3–17.8 | 12.2–12.7 | 5.1 | B | 20 | 20 |
| DN-W-17.7-12.1 | 17.3–18.1 | 11.7–12.5 | 5.6 | B | 20 | 20 |
| TRANSMIT BAND TO L-BAND | | | | | | |
| DN-W-6-1.2 | 5.925–6.425 | 0.95–1.45 | 4.975 | B | 23 | 18 |
| DN-W-6-1.2-INV | 5.925–6.425 | 0.95–1.45 | 7.375 | B | 23 | 18 |
| DN-W-13-1.2 | 12.75–13.25 | 0.95–1.45 | 11.8 | D | 20 | 18 |
| DN-W-14-1.2 | 14.0–14.5 | 0.95–1.45 | 13.05 | E | 20 | 18 |
| DN-W-17.55-1.2 | 17.3–17.8 | 0.95–1.45 | 16.35 | E | 20 | 18 |
| DN-W-17.7-1.35 | 17.3–18.1 | 0.95–1.75 | 16.35 | E | 20 | 18 |

FUNCTIONAL

| | |
|---------------------------------|---|
| Conversion loss..... | 12 dB maximum, 15 dB maximum with Options 1 or 2 |
| Amplitude response..... | ±0.25 dB over any 40 MHz, ±1 dB over output frequency band |
| Frequency stability..... | ±5 x 10 ⁻⁶ (-30 to +60°C) |
| Level control..... | 30 dB minimum |
| Intermodulation distortion..... | With two inband input signals at -13 dBm, third order intermodulation products are less than 50 dBc |
| Input/output isolation..... | 60 dB minimum |
| Phase noise..... | Refer to graph and code letter in table |

FUNCTIONAL BLOCK DIAGRAM

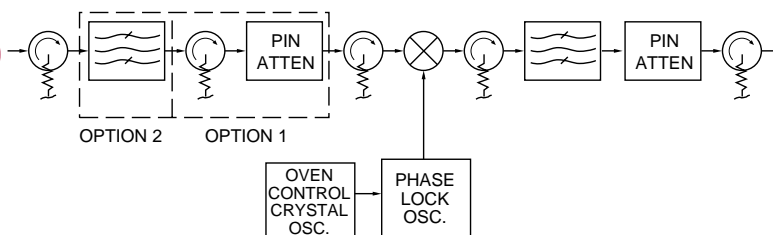

OPTIONS

1. 30 dB additional level control.
 - A. 60 dB level control. Simultaneous control of input and output attenuators.
 - B. 60 dB level control. Independent control of input and output attenuators (not available if combined with Option 17).
2. Input filter.
5. Higher frequency stability reference. $\pm 1 \times 10^{-6}$ /day (-30 to +60°C). Refer to factory for higher stability options.
6. 5 MHz reference configuration (not available for DN-W-14.65-11.85).
 - A. No internal reference. External 5 MHz reference at 0 ± 3 dBm.
 - D. Automatic reference switchover.
An internal 5 MHz reference and rear panel connector for external reference input (0 ± 3 dBm) is provided. The local oscillator will lock to the external reference. If external reference is not present, the local oscillator will automatically lock to the internal reference. Internal reference frequency stability is $\pm 5 \times 10^{-8}$ (-30 to +60°C).
7. Summary alarm. Contact closure for DC power and/or local oscillator fault.
8. Input/output amplifiers. Refer to factory for available options.
17. Remote control/digitally controlled attenuator. 30 dB level control in 0.2 dB step size. 60 dB level control in 1.0 dB step size if ordered with Option 1A.
 - A. RS422 remote interface.
 - B. RS485 remote interface.
 - C. RS232 remote interface.
26. Pressurization.
Translator enclosure capable of 0.5 PSI.
Leak rate: 3.0 standard cubic feet per hour maximum.
1/4 inch hose diameter recommended.

Note: Missing option numbers are not applicable for these systems.

PHASE NOISE

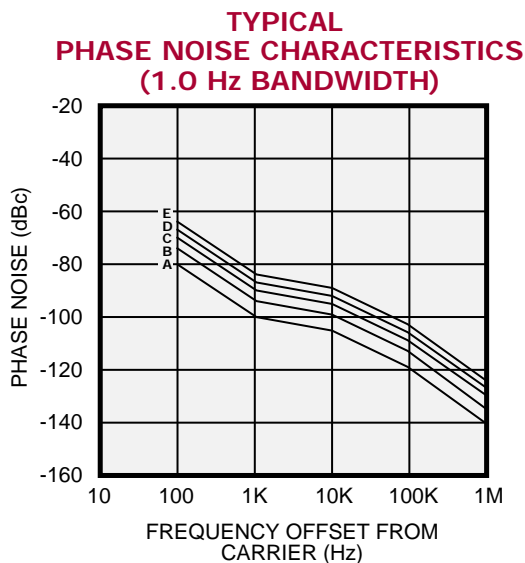

OUTLINE

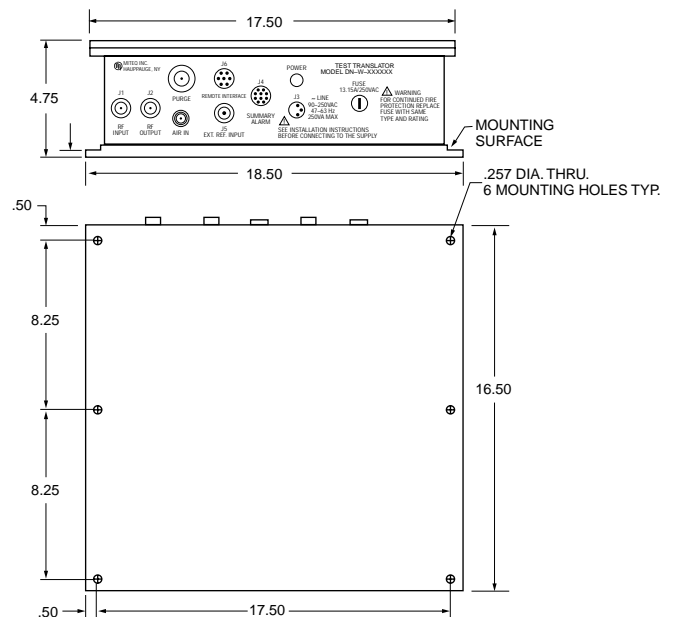

TEST TRANSLATORS

For Outdoor Applications

PRIMARY POWER REQUIREMENTS

Voltage 90–250 VAC
Frequency 47–63 Hz
Power consumption 150 W typical

PHYSICAL

Weight 45 pounds nominal
Dimensions 17.5" x 17.5" x 4.75" (refer to outline drawing)

Connectors

- RF input and RF output N female
- External reference input
(Option 6) N female
- Summary alarm connector
(Option 7) MS3102R18-1S (mating connector supplied)
- Remote interface connector
(Option 17) MS3102R16-1S for RS485, RS422,
and RS232
- AC input connector CL1M1102 (mating connector supplied)

Test points

- DC voltage Jack (internal panel)
- LO phase voltage Jack (internal panel)
- LO frequency/power monitor SMA female (internal panel)

ENVIRONMENTAL

Operating

- Ambient temperature -30 to +60°C
- Atmospheric pressure Up to 10,000 feet

Nonoperating

- Temperature -50 to +70°C
- Atmospheric pressure Up to 40,000 feet
- Shock and vibration Normal handling by commercial carriers

Note: For more detailed description, refer to MITEQ Technical Note 25T040.



100 Davids Drive, Hauppauge, NY 11788
TEL.: (631) 436-7400 • FAX: (631) 436-7431/436-7430
www.miteq.com