

FOUR-CHANNEL DOWNCONVERTER MODULE

MODEL SERIES: DA4

FEATURES

- RF/LO coverage 0.5 to 18 GHz
- Input limiter diode protection
- Conversion gain 25 dB typical
- Noise figure 8.5 dB typical
- Channel-to-channel tracking
 - Phase $\pm 5^\circ$ typical
 - Amplitude ± 0.5 dB typical

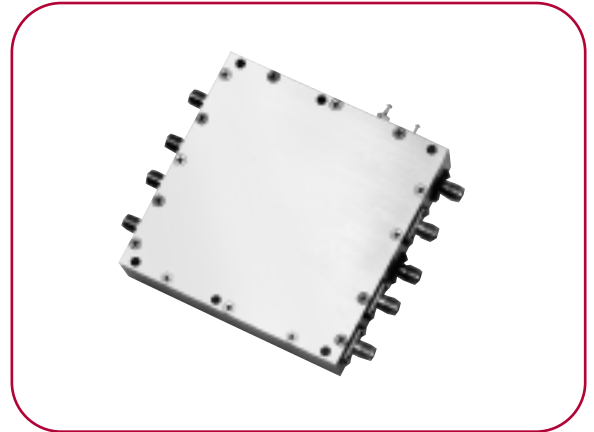

MITEQ's Model DA4 Series integrates our standard broadband double-balanced mixer designs with input limiter protection diodes and IF amplifiers to provide a phase- and amplitude-tracked four-channel downconverter with an integrated LO distribution network. This unit can be used for basic direction finding (D.F.) experiments with four antennas. In addition, three of the four channels can also be used for a monopulse radar receiver and the fourth used for spur identification.

ELECTRICAL SPECIFICATIONS

INPUT PARAMETERS	CONDITION	UNITS	MIN.	TYP.	MAX.
RF/LO frequency range	DA40502LC7	GHz	0.5		2
	DA40208LC7	GHz	2		8
	DA40818LC7	GHz	8		18
Maximum RF input power	CW	Watts	1		
	Pulse (1 μ s, 1% duty cycle)	Watts	50		
LO power range		dBm	+13	+15	
RF and LO VSWR (RF = -10 dBm, LO = +15 dBm)		Ratio		2:1	3:1
DC bias +15 V		mA		150	
TRANSFER CHARACTERISTICS	CONDITION	UNITS	MIN.	TYP.	MAX.
Conversion gain (RF input to IF output)		dB	23	25	
Single-sideband noise figure at 25°C	0.5 to 4 GHz	dB		8	10
	4 to 18 GHz	dB		9	11
LO-to-RF isolation		dB	20	25	
LO-to-IF isolation		dB		20	
RF-to-IF isolation		dB		20	
Output power at 1 dB compression	LO = +15 dBm	dBm		+10	
Output two-tone third-order intercept point	LO = +15 dBm	dBm		+20	
Channel-to-channel amplitude tracking		dB		± 0.5	± 1
Channel-to-channel phase tracking		Degrees		± 5	± 10
OUTPUT PARAMETERS	CONDITION	UNITS	MIN.	TYP.	MAX.
IF frequency range		MHz	10		250
IF VSWR (IF = -10 dBm, LO = +15 dBm)		Ratio		2:1	

DA40204L TYPICAL TEST DATA

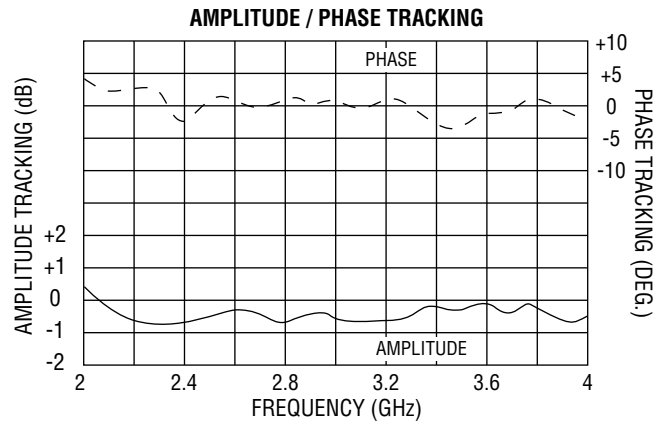
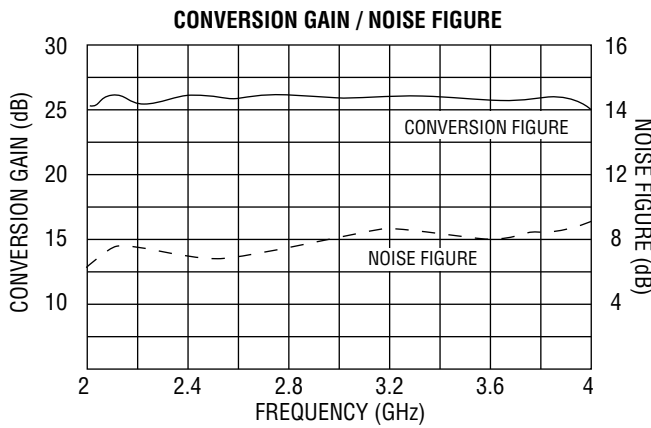
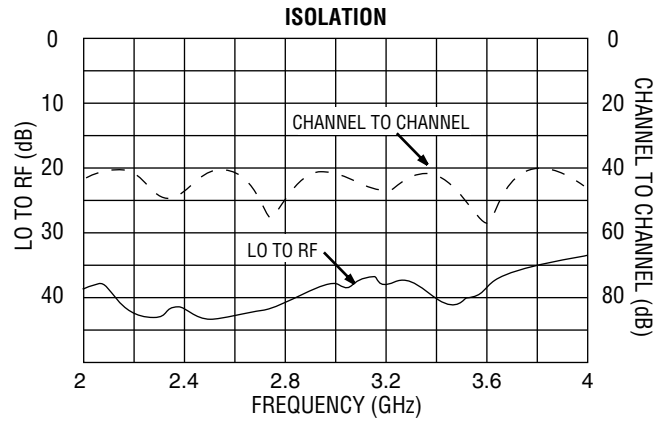
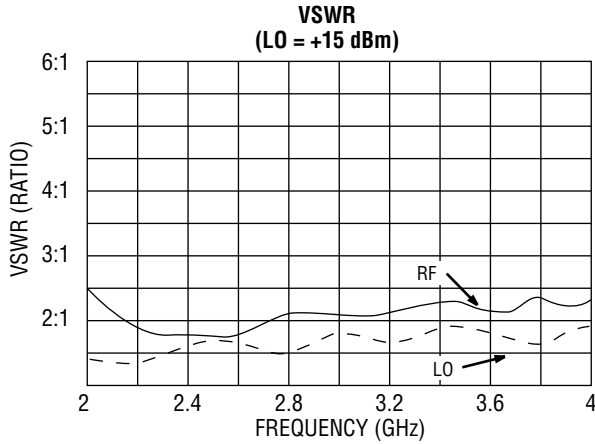

MAXIMUM RATINGS

Operating temperature -54 to +85°C
 Storage temperature -65 to +125°C

AVAILABLE OPTIONS

Multioctave RF coverage.
 RF built-in-test (BIT) input.
 Microwave IF coverage.
 High dynamic range operation.

NOTE: Test data supplied at 25°C; conversion gain, LO-to-RF isolation, noise figure, amplitude and phase balance.

OUTLINE DRAWING

FUNCTIONAL BLOCK DIAGRAM

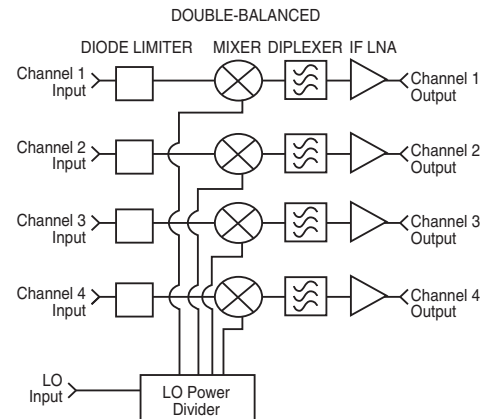
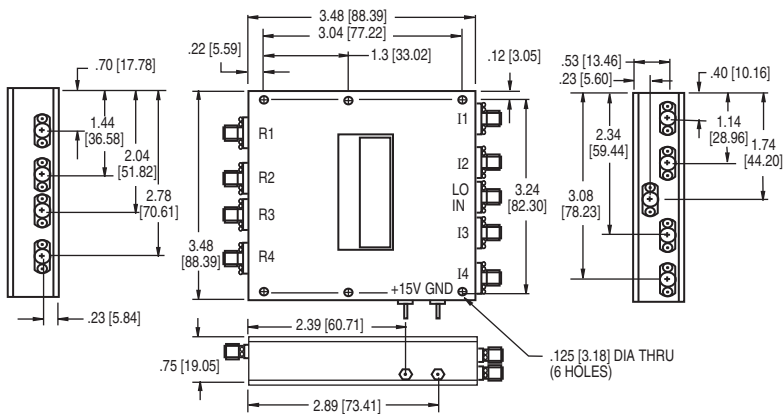

NOTE: All dimensions shown in brackets [] are in millimeters.