



1:1, DUAL 1:1 AND 1:2 REDUNDANT LINE AMPLIFIER SYSTEMS



1:1 UNIT



DUAL 1:1 UNIT



1:2 UNIT

FEATURES

- Fault tolerant design
- Fully redundant, hot swappable power supplies
- Remote control via RS485 or RS422 user selectable
- Automatic/manual control from both local and remote mode
- Remote status
- Off-line input/output access
- Amplifier current fault detection
- Time-stamped alarm history

The 1:1, dual 1:1 and 1:2 redundant line amplifier systems are designed to ensure continuous operation without disruption of signal transmission.

A fault condition in the on-line amplifier, or an operator generated command, will switch the standby amplifier to the on-line position and remove the on-line amplifier from the signal path.

OPTIONS

- Remote RS232 or contact closure
- Input/output signal monitors
- Level control
- Higher gain
- Increased output power

SPECIFICATIONS

Frequency (GHz)	1:1 Model Number	1:2 Model Number	Dual 1:1 Model Number
0.95 – 1.45	RL1-095145*	RL2-095145*	RL3-095145*
0.95 – 1.75	RL1-095175*	RL2-095175*	RL3-095175*
0.95 – 2.15	RL1-095215*	RL2-095215*	RL3-095215*
1.5 – 1.8	RL1-150180	RL2-150180	RL3-150180
2.0 – 2.7	RL1-200270	RL2-200270	RL3-200270
3.4 – 4.2	RL1-340420	RL2-340420	RL3-340420
4.5 – 4.8	RL1-450480	RL2-450480	RL3-450480
5.725 – 6.725	RL1-572672	RL2-572672	RL3-572672
5.845 – 6.430	RL1-584643	RL2-584643	RL3-584643
6.4 – 7.2	RL1-640720	RL2-640720	RL3-640720
7.25 – 8.4	RL1-725840	RL2-725840	RL3-725840
10.7 – 12.75	RL1-107128	RL2-107128	RL3-107128
13.75 – 14.8	RL1-137148	RL2-137148	RL3-137148
17.7 – 21.2	RL1-177212	RL2-177212	RL3-177212
17.7 – 22.0	RL1-177220	RL2-177220	RL3-177220
27.5 – 31.0	RL1-275310*	RL2-275310*	RL3-275310*
31.0 – 33.0	RL1-310330*	RL2-310330*	RL3-310330*

* References input/output return loss specification.

Gain	30 dB minimum (higher gain optional)
Gain flatness.....	0.4 dB/any 40 MHz, 1.0 dB peak-to-peak/RF bands up to 500 MHz, 1.5 dB peak-to-peak/RF bands up to 800 MHz, 2.0 dB peak-to-peak/RF bands greater than 800 MHz
Gain slope.....	0.2 dB/10 MHz maximum
Gain stability	±0.2 dB/24 hours (constant temperature)
Power output (1 dB compression)	+10 dBm minimum (higher output power optional)
Channel-to-channel gain match	2 dB maximum
Noise figure	
Below 4.2 GHz	3 dB maximum
4.2 GHz to 12.75 GHz.....	4 dB maximum
12.75 GHz to 14.5 GHz.....	5 dB maximum
Above 14.5 GHz	8 dB maximum
Spurious outputs.....	Below thermal noise
AM/PM conversion	0.5°/dB maximum to 0 dBm output
Isolation	50 dB minimum
Input return loss	20 dB minimum *10 dB minimum (refer to table)
Input/output impedance	50 ohms

PRIMARY POWER REQUIREMENTS

Voltage	90–250 VAC
Frequency.....	47–63 Hz
Power consumption.....	40 W typical

SUMMARY ALARM

Contact closure/open for DC voltage and/or amplifier alarm
Status alarm readout on remote control bus

SPECIFICATIONS (CONT.)

PHYSICAL

AC input connectors.....	IEC-320
RF connectors.....	SMA female, 3.5 mm compatible above 22 GHz
Summary alarm interface mating connector	DEM-9P
Remote interface	DEM-9S for RS485 and RS422, DB-25P for RS232, DB-37S for contact closure, IEEE-488 receptacle for GPIB
Weight.....	20 pounds typical
Overall dimensions.....	19" x 1.75" panel x 22" maximum (chassis depth 20")

ENVIRONMENTAL

Operating

Ambient temperature	0 to 50°C
Relative humidity.....	Up to 95% at 30°C
Atmospheric pressure.....	Up to 10,000 feet

Nonoperating

Temperature.....	-50 to +70°C
Relative humidity.....	Up to 95% at 40°C
Atmospheric pressure.....	Up to 40,000 feet
Shock and vibration	Normal handling by commercial carriers

1:1 REDUNDANT LINE AMPLIFIER FUNCTIONAL BLOCK DIAGRAM

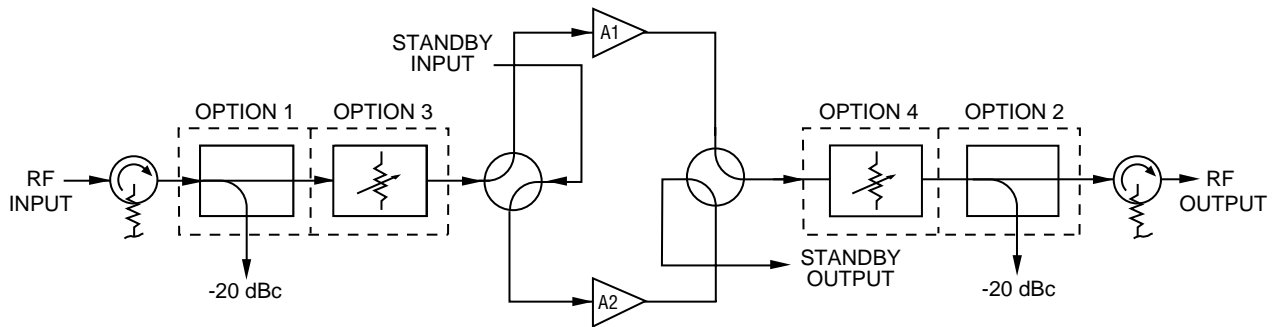

1:2 REDUNDANT LINE AMPLIFIER FUNCTIONAL BLOCK DIAGRAM

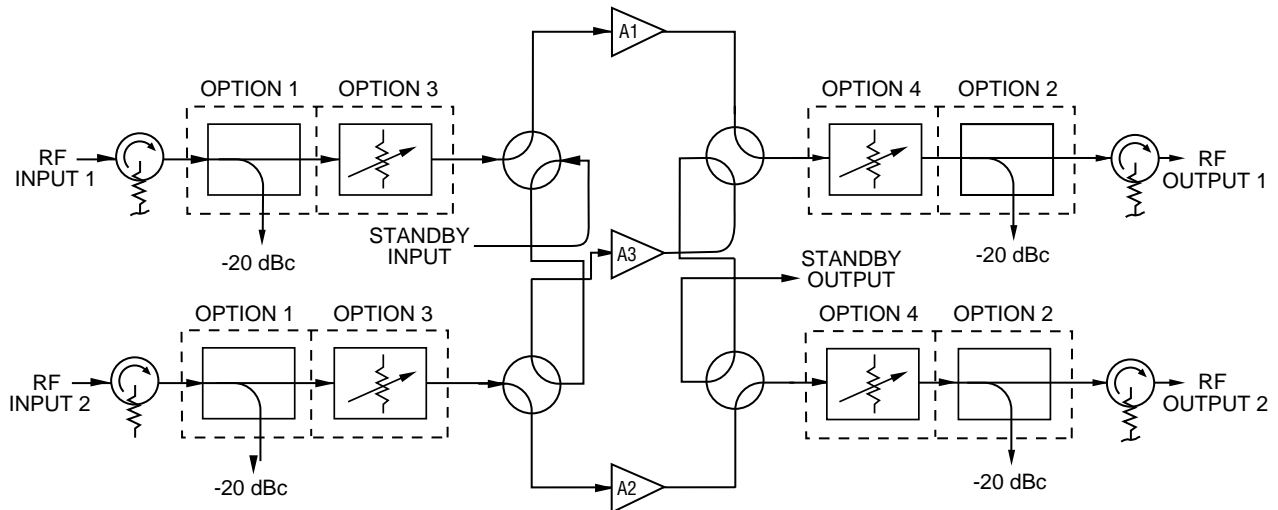

1:1, DUAL 1:1 AND 1:2 REDUNDANT LINE AMPLIFIER SYSTEMS

OPTIONS

1. RF input monitor with -20 dBc nominal level.
2. RF output monitor with -20 dBc nominal level.
3. Input level control, 30 dB in 0.2 dB steps, local and remote control.
4. Output level control, 30 dB in 0.2 dB steps, local and remote control.
11. Increased output power.
 - A. +15 dBm output power at 1 dB compression.
 - B. +20 dBm output power at 1 dB compression.
16. Higher gain.
 - A. 40 dB minimum gain.
 - B. 50 dB minimum gain.
17. Remote control.
 - B. RS422/485 (supplied as standard).
 - C. RS232.
 - D. Contact closure.

- Notes: 1. Options 1 and 3 will degrade noise figure proportional to insertion loss of devices inserted before amplifiers.
2. Options 2 and 4 will reduce output power compression point proportional to insertion loss of devices inserted after amplifier.

Missing option numbers are not applicable to this product.

For literature describing local control and remote control (bus protocols), refer to MITEQ's Technical Note 25T043.

TYPICAL REAR PANEL VIEW

RL1 SERIES



RL2 SERIES



RL3 SERIES



- Ground lug Power supply A AC voltage input/switch Power supply B AC voltage input/switch Summary alarm connector Remote interface connectors



D-238B

100 Davids Drive, Hauppauge, NY 11788
TEL.: (631) 436-7400 • FAX: (631) 436-7431/436-7430
www.miteq.com