



1:1 AND 1:2 REDUNDANT LOW- NOISE Ka-BAND BLOCK CONVERTER SYSTEMS



1:1
CONTROLLER



1:2
CONTROLLER

FEATURES

- Low noise temperature downconverters
- Fault tolerant design
- Redundant hot-swappable power supplies
- Remote control and status via RS422 or RS485 user selectable
- Automatic/manual control
- Off-line input/output access
- Time stamped event history
- Continuous operation during fault repair or maintenance

OPTIONS

- Remote RS232 or contact closure
- Ethernet interface
- High stability reference
- Input/output signal monitors
- Remote control unit

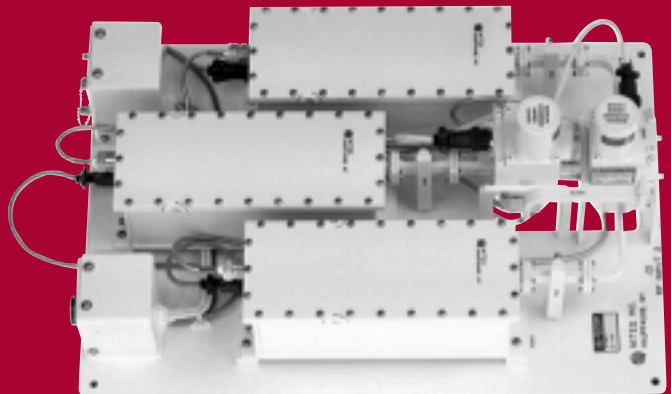

The 1:1 and 1:2 redundant low-noise block (LNB) converter systems are designed to ensure continuous operation without disruption of signal transmission.

A fault condition in the on-line LNB, or an operator generated command, will switch the standby LNB to the on-line position and remove the on-line LNB from the signal path.

The redundant LNB system consists of an outdoor LNB/switch assembly, rack mounted local control unit and interconnect cable.

SPECIFICATIONS

Model Number	Model Number	Input Frequency (GHz)	Output Frequency (GHz)
RB1-183188	RB2-183188	18.3 – 18.8	0.95 – 1.45
RB1-197202	RB2-197202	19.7 – 20.2	0.95 – 1.45
RB1-202212	RB2-202212	20.2 – 21.2	0.95 – 1.95
RB1-202212-1	RB2-202212-1	20.2 – 21.2	1 – 2

RF specifications

Type..... Single conversion

Frequency sense No inversion

Input characteristics

Impedance 50 ohms

Return loss..... 18 dB minimum

Output characteristics

Impedance 50 ohms

Return loss..... 15 dB minimum

Power output (1 dB compression) +10 dBm minimum

Transfer characteristics

Gain 50 dB minimum

Image rejection 80 dB minimum

Level stability

Constant temperature ± 0.25 dB/day maximum

Over operating temperature 2 dB maximum

Noise temperature 150°K maximum at 23°C (excludes input switch and Option1)

Amplitude response ± 0.5 dB/ ± 40 MHz, ± 2.0 dB over RF-band

Group delay 1 ns peak-to-peak maximum

Intermodulation distortion (third order)..... With two 0 dBm output signals, 20 dBc minimum

Signal related spurious 65 dBc minimum up to 0 dBm output level

Signal independent spurious -70 dBm maximum

LO leakage at RF..... -70 dBm maximum

Frequency stability $\pm 5 \times 10^{-8}$, -40 to +60°C (higher stability options available),
 $\pm 5 \times 10^{-9}$ /day typical (fixed temperature after 24 hour on time)

Automatic reference configuration External 5 or 10 MHz at +4 ± 3 dBm

If external reference is below +1 dBm nominal,
the converter will automatically lock to the internal reference

Isolation between any path 50 dB minimum

OPTIONS

1. Test input inject crossguide coupler, 40 dB nominal coupling level.
2. Output test coupler, 20 dB nominal coupling level.
- 6-(x). Local control unit to LNB/switch assembly cable length. (x) is the length of the cable in feet. Available from 10 to 400 feet in 10 foot increments. 100 foot cable supplied as standard.
10. Higher frequency stability reference.
 $\pm 5 \times 10^{-9}$, -40 to +60°C
 1×10^{-9} /day typical (fixed temperature after 24 hour on time).
17. Remote control.
 - C. RS232.
 - D. Contact closure.
 - H. 10/100 Base-T Ethernet interface providing:
Web-browser-based configuration, SNMP 1.0 configuration, alarm reporting via SNMP trap, telnet access, password protection.

Note: Missing option numbers are not applicable to this product.

1:1 REDUNDANT LNB SYSTEM BLOCK DIAGRAM

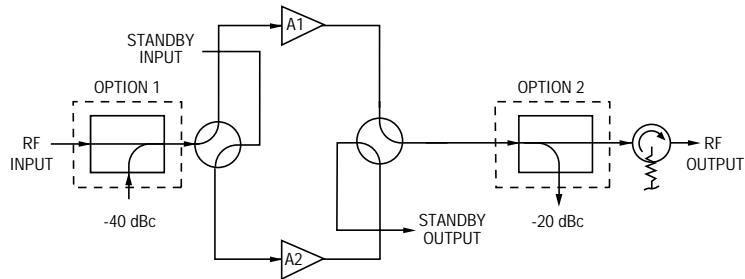

1:2 REDUNDANT LNB SYSTEM BLOCK DIAGRAM

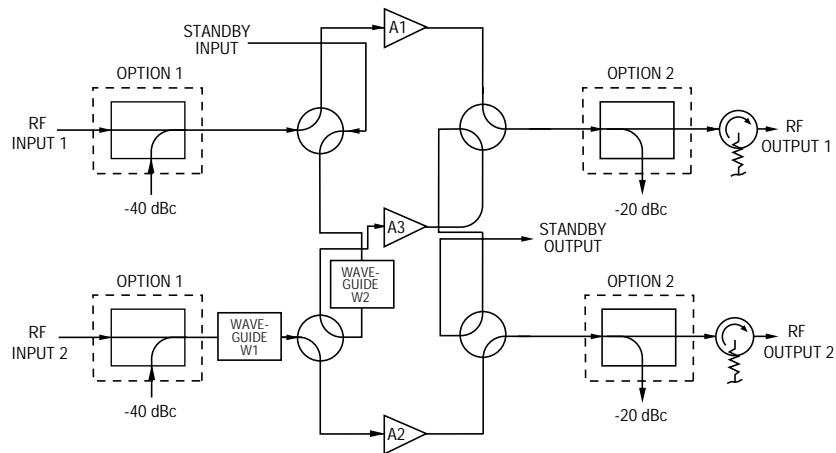

Typical system noise temperature calculation:

1:1 Redundant LNB System:

$$T_{\text{system}} = T_{\text{LNB}} + T_{\text{SWITCH}} + T_{\text{OPTION 1}}$$

1:2 Redundant LNB System:

RF input 1: LNB 1 on-line signal path

$$T_{\text{system}} = T_{\text{LNB}} + T_{\text{SWITCH}} + T_{\text{OPTION 1}}$$

RF input 1: LNB 3 on-line signal path (LNB 1 standby)

$$T_{\text{system}} = T_{\text{LNB}} + 2 * T_{\text{SWITCH}} + T_{\text{W2}} + T_{\text{OPTION 1}}$$

RF input 2: LNB 2 on-line signal path

$$T_{\text{system}} = T_{\text{LNB}} + T_{\text{W1}} + T_{\text{SWITCH}} + T_{\text{OPTION 1}}$$

RF input 1: LNB 3 on-line signal path (LNB 2 standby)

$$T_{\text{system}} = T_{\text{LNB}} + 2 * T_{\text{SWITCH}} + T_{\text{W1}} + T_{\text{W2}} + T_{\text{OPTION 1}}$$

Typical Noise Temperature in Kelvin at 23°C

Band (GHz) 17.7-22.0

Band (GHz)	17.7-22.0
WR-42	
T_{SWITCH}	19°
T_{W1}	7°
T_{W2}	11°
$T_{\text{OPTION 1}}$	12°

PHASE NOISE CHARACTERISTICS (1.0 Hz BANDWIDTH)

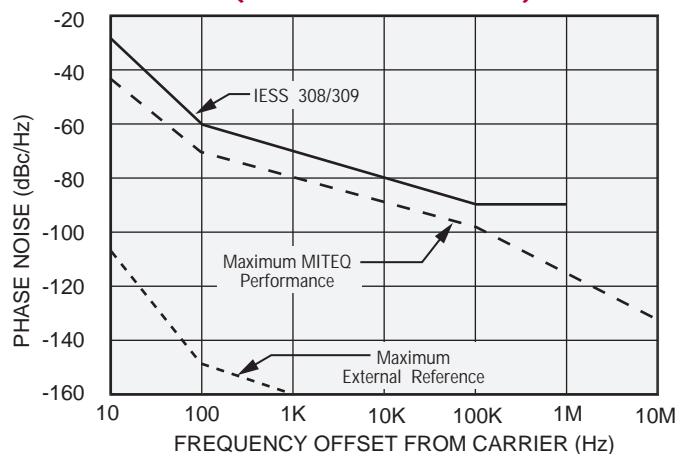

1:1 AND 1:2 REDUNDANT LOW-NOISE Ka-BAND BLOCK CONVERTER SYSTEMS

CONTROLLER PRIMARY POWER REQUIREMENTS

Voltage	90–250 VAC
Frequency	47–63 Hz
Power	50 W typical

SUMMARY ALARM

Contact closure, open for DC voltage and/or summary alarm

Status alarm readout on remote bus

PHYSICAL

Controller AC input connector	IEC-320
RF input connector	WR42 grooved
RF output connectors	Type “N” female
Summary alarm interface mating connector	DEM-9P
Remote interface	DEM-9S for RS422/RS485, DB-25P for RS232, DB-37 for contact closure, RJ-45 female for Ethernet
Weight (LNB plate)	30 pounds typical
Overall dimensions (Controller)	19” x 1.75” panel x 22” maximum
Overall dimensions (LNB plate)	12.50” x 18.00” x 10.50” height maximum

ENVIRONMENTAL

Operating

Ambient temperature (Controller)	0 to 50°C
Ambient temperature (LNB plate)	-40 to +60°C
Relative humidity	Up to 95% at 30°C
Atmospheric pressure	Up to 10,000 feet

Nonoperating

Ambient temperature	-50 to +70°C
Relative humidity	Up to 95% at 40°C
Atmospheric pressure	Up to 40,000 feet
Shock and vibration	Normal handling by commercial carriers



100 Davids Drive, Hauppauge, NY 11788
TEL.: (631) 436-7400 • FAX: (631) 436-7431
www.miteq.com