



1/3 RACK BLOCK CONVERTERS APPLICATIONS



FEATURES

- Compact Unit
- Low power consumption
- Low intermodulation distortion
- Low phase noise
- Automatic 5/10 MHz internal/ external reference selection
- Gain control
- RF- and L-band signal monitor ports
- High frequency stability
- Summary alarm
- Mute function on alarm or external mute input command
- LO frequency and power monitor
- CE Mark

OPTIONS

- High performance phase noise
- Higher frequency stability
- RS422/RS485 and 10/100 Base-T Ethernet

These Block Converters are designed for 1/3 rack systems enabling a wide range of different functional configurations.

The functions are:

- L to RF Block Upconverters
- RF- to L-band Block Downconverters
- RF Transmit to Receive-Band Test Translators
- RF Transmit to L-Band Test Translators
- 1:1 Redundant Switchover Unit

Each functional assembly consists of:

- Component related to the function
- Power supply
- Front panel control
- Auto switch 5/10 MHz reference
- Remote control

APPLICATIONS

- All Standard Earth Stations
- Broadcast Earth Stations
- VSAT Earth Stations
- Mobile Earth Stations
- Transportable Earth Stations
- Military and Commercial

Patent Pending



BLOCK CONVERTERS

BLOCK UPCONVERTERS

Input (GHz)	Output (GHz)	LO (GHz)	Model Number
0.95–1.525	5.85–6.425	7.375	UPB1-6.1TR-INV
0.95–1.75	5.85–6.65	4.9	UPB1-6.25TR
0.95–1.35	6.7–7.1	5.75	UPB1-6.9TR
0.95–1.45	7.9–8.4	6.95	UPB1-8.15TR
0.95–1.45	12.75–13.25	11.8	UPB1-13TR
0.95–1.7	13.75–14.5	12.8	UPB1-14.125TR
0.95–1.45	14–14.5	13.05	UPB1-14.25TR
0.95–1.75	17.3–18.1	16.35	UPB1-17.7TR
0.95–2.05	17.3–18.4	16.35	UPB1-17.85TR
0.95–1.25	18.1–18.4	17.15	UPB1-18.25TR
Ka-Band			
0.95–1.2	28.35–28.6	27.4	UPB1-28.475TR
0.95–1.45	29–29.5	28.05	UPB1-29.25TR
0.95–1.2	29.25–29.5	28.3	UPB1-29.375TR
0.95–1.7	29.25–30	28.3	UPB1-29.625TR
0.95–1.95	30–31	29.05	UPB1-30.5TR
1–2	30–31	29	UPB1-30.5-1TR

Note: For additional details on specifications, please refer to data sheet D-321.

BLOCK DOWNCONVERTERS

Input (GHz)	Output (GHz)	LO (GHz)	Model Number
3.4–4.2	0.95–1.75	5.15	DNB1-3.8TR-INV
3.4–4.2	0.95–1.75	8.55/11	DNB1-3.8TR
3.7–4.2	0.95–1.45	8.55/11.3	DNB1-3.95TR
7.25–7.75	0.95–1.45	6.3	DNB1-7.5TR
10.7–11.7	0.95–1.95	9.75	DNB1-11.2TR
10.95–11.7	0.95–1.7	10	DNB1-11.35TR
11.2–12	0.95–1.75	10.25	DNB1-11.6TR
11.45–12.25	0.95–1.75	10.5	DNB1-11.85TR
11.7–12.5	0.95–1.75	10.75	DNB1-12.1TR
11.7–12.75	0.95–2	10.75	DNB1-12.225TR
12.2–12.75	0.95–1.5	11.25	DNB1-12.475TR
Ka-Band			
18.3–18.8	0.95–1.45	17.35	DNB1-18.55TR
19.7–20.2	0.95–1.45	18.75	DNB1-19.95TR
20.2–21.2	0.95–1.95	19.25	DNB1-20.7TR
20.2–21.2	1–2	19.2	DNB1-20.7-1TR
28.3–28.8	0.95–1.45	27.35	DNB1-28.55TR
29.25–29.5	0.95–1.2	28.3	DNB1-29.375TR
29.25–30	0.95–1.7	28.3	DNB1-29.625TR

TEST TRANSLATORS

RF TRANSMIT-BAND TO RF RECEIVE-BAND

Input (GHz)	Output (GHz)	LO (GHz)	Model Number
5.85–6.425	3.625–4.2	2.225	DNS-6.1/3.9TR
5.85–6.65	3.4–4.2	2.45	DNS-6.25/3.8TR
6.725–7.025	4.5–4.8	2.225	DNS-6.8/4.6TR
7.9–8.4	7.25–7.75	0.65	DNS-8.15/7.5TR
7.9–8.4	7.175–7.675	0.725	DNS-8.15/7.4TR
12.75–13.25	10.7–11.2	2.05	DNS-13/11.2TR
13.75–14.5	10.7–11.45	3.05	DNS-14/11TR
13.75–14.5	11.45–12.2	2.3	DNS-14/11.8TR
13.75–14.5	12–12.75	1.75	DNS-14/12.3TR
13.75–14.5	10.95–11.7	2.8	DNS-14/11.3TR
13.75–14.5	11.7–12.45	2.05	DNS-14/12TR
17.3–18.1	11.7–12.5	5.6	DNS-17.7/12.1TR
Ka-Band			
29.5–30	19.2–19.7	10.3	DNS-29.75/19.45TR
29.5–30	19.7–20.2	9.8	DNS-29.75/19.95TR
29–30	19.2–20.2	9.8	DNS-29.5/19.7TR
30–31	20.2–21.2	9.8	DNS-30.5/20.7TR

RF TRANSMIT-BAND TO L-BAND

Input (GHz)	Output (GHz)	LO (GHz)	Model Number
5.85–6.65	0.95–1.75	4.9	DN1-6.25TR
5.925–6.425	0.95–1.45	7.375	DN1-6.175TR-INV
7.9–8.4	0.95–1.45	6.95	DN1-8.15TR
12.75–13.25	0.95–1.45	11.8	DN1-13TR
14–14.5	0.95–1.45	13.05	DN1-14.25TR
13.75–14.5	0.95–1.7	12.80	DN1-14.125TR
14.5–14.8	0.95–1.25	13.55	DN1-14.65TR
17.3–18.1	0.95–1.75	16.35	DN1-17.7TR
Ka-Band			
28.35–28.6	0.95–1.2	27.4	DN1-28.475TR
29.25–29.5	0.95–1.2	28.3	DN1-29.375TR
29.25–30	0.95–1.7	28.3	DN1-29.75TR
30–31	0.95–1.95	29.05	DN1-30.5TR
30–31	1–2	29	DN1-30.5-1TR

Note: For additional details on specifications, please refer to data sheet D-320.

1:1 SWITCHOVER UNIT

1:1 SWITCHOVER UNIT SINGLE TRANSFER SWITCH MODEL

Model Number	Frequency Range (GHz)	Connectors
RSU-S-TR	0.95–18.4	SMA
RSU-K-TR	18.4–31	2.92 mm

Note: For additional details on specifications, please refer to data sheet D-322.

1:1 SWITCHOVER UNIT DUAL TRANSFER SWITCH MODEL

Model Number	Frequency Range (GHz)	Connectors
RSU-S/S-TR	0.95–18.4	SMA
RSU-S/K-TR	0.95–18.4/18.4–31	SMA/2.92 mm
RSU-K/K-TR	18.4–31	2.92 mm

1:1 REDUNDANT BLOCK UPCONVERTERS

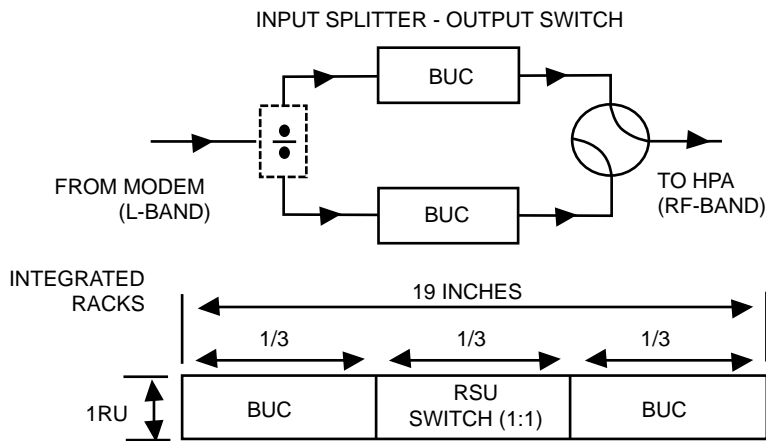
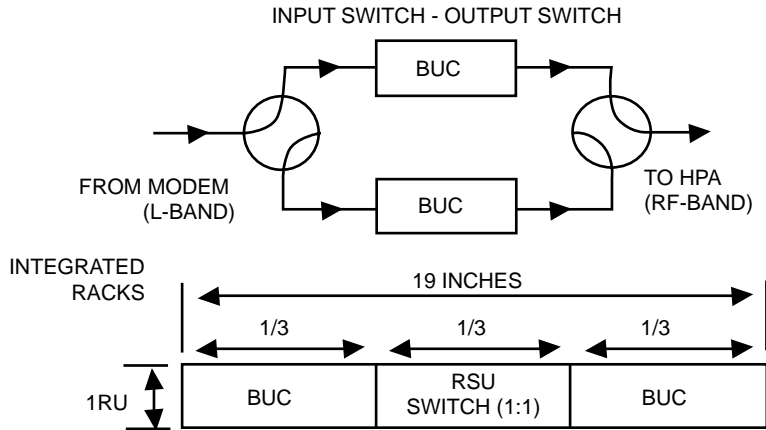

Note: Splitter is customer supplied.

1:2 REDUNDANT BLOCK UPCONVERTERS

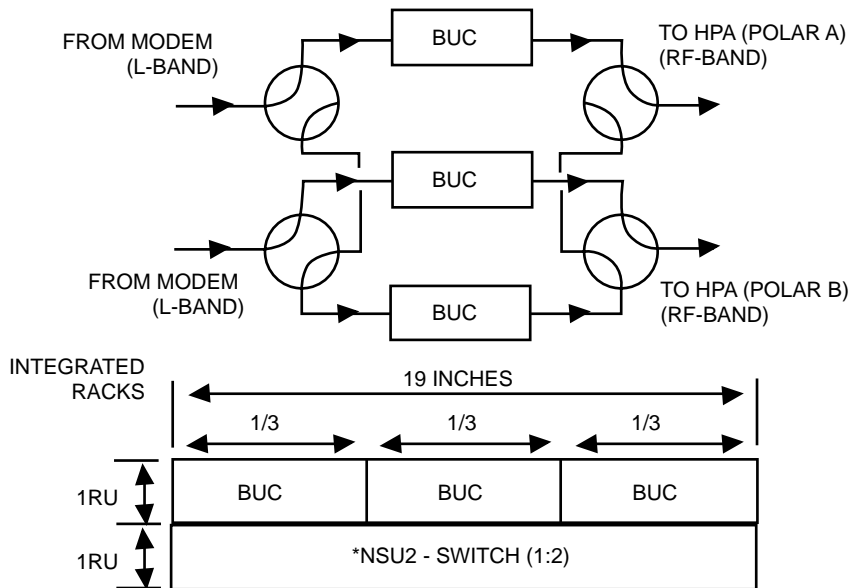

* NSU2 ordered for use with 1/3 rack converters need a special cable set.

1:1 REDUNDANT BLOCK DOWNCONVERTERS

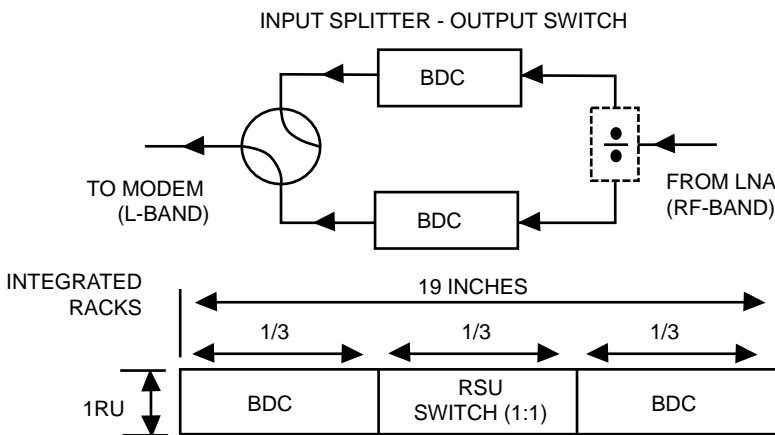
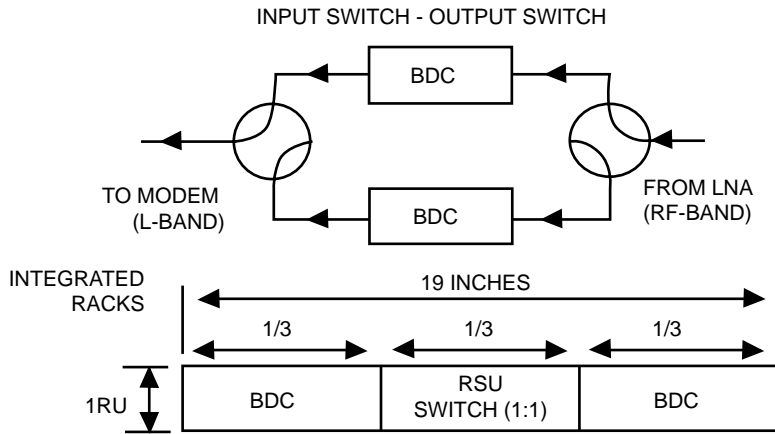

Note: Splitter is customer supplied.

1:2 REDUNDANT BLOCK DOWNCONVERTERS

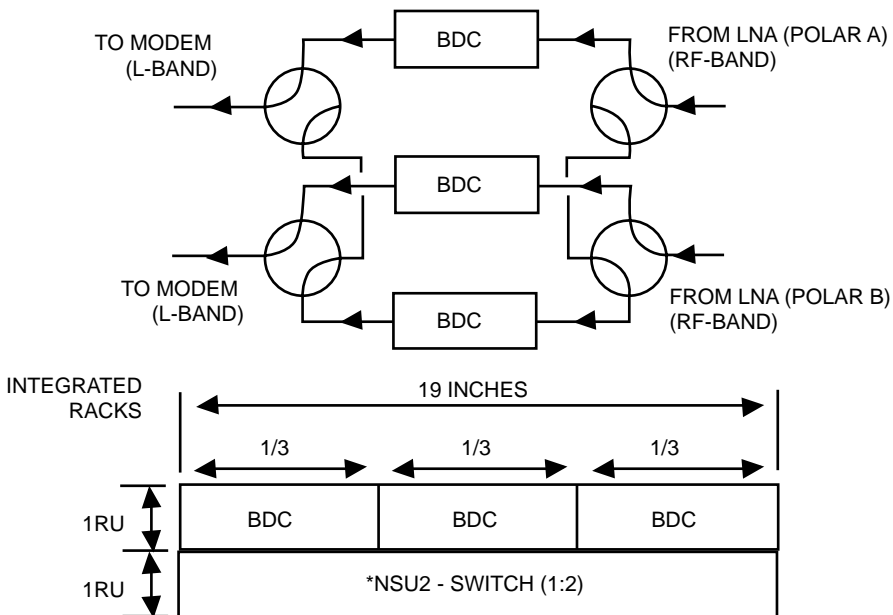

* NSU2 ordered for use with 1/3 rack converters need a special cable set.

RF TRANSMIT-BAND TO L-BAND TEST TRANSLATORS

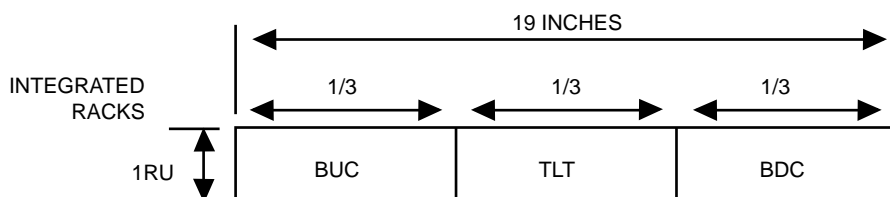
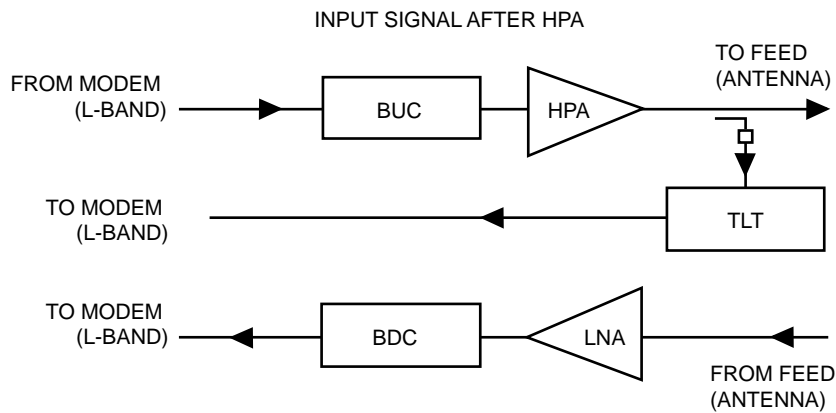
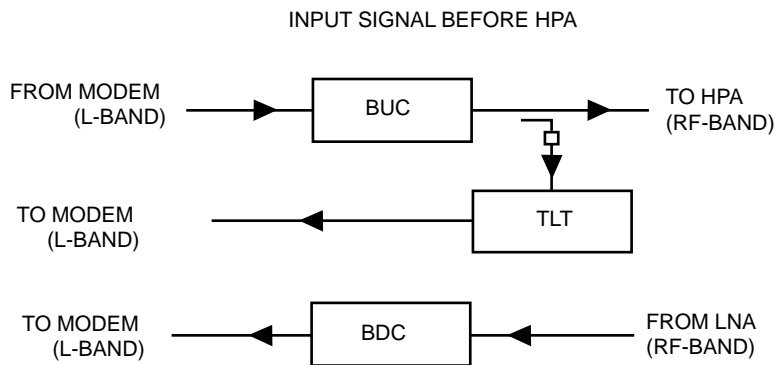

1/3 RACK BLOCK CONVERTERS APPLICATIONS

RF TRANSMIT-BAND TO RF RECEIVE-BAND TEST TRANSLATORS

